

Ultrasound

1 Ultrasound has many different applications.

(a) (i) Complete the sentence by putting a cross (☒) in the box next to your answer.

Ultrasound is used for

(1)

- A** cooking
- B** communication between animals
- C** communication with satellites
- D** detecting forged bank notes

(ii) Explain why ultrasound rather than X-rays are used for foetal scanning.

(2)

.....

.....

.....

.....

(b) An ultrasound wave vibrates 30 000 times a second.

(i) State the frequency of the wave.

(1)

.....

.....

.....

.....

(ii) Describe the motion of particles in a material when this ultrasound wave passes through.

(2)

*(c) Explain how sonar is used by deep sea fishermen to detect the depth of a shoal of fish below the surface of the sea.

(6)

.....

.....

.....

.....

.....

.....

.....

.....

.....

.....

.....

.....

.....

.....

.....

.....

.....

.....

.....

.....

.....

.....

(Total for Question 5 = 12 marks)

2 (a) A student is sta

A firework explodes with a loud bang, and a flash of light is seen.

Describe how a student can measure the time it takes for the sound wave from the loud bang to travel 600 m.

(2)

.....

.....

.....

.....

(b) Figure 2 shows a water wave.

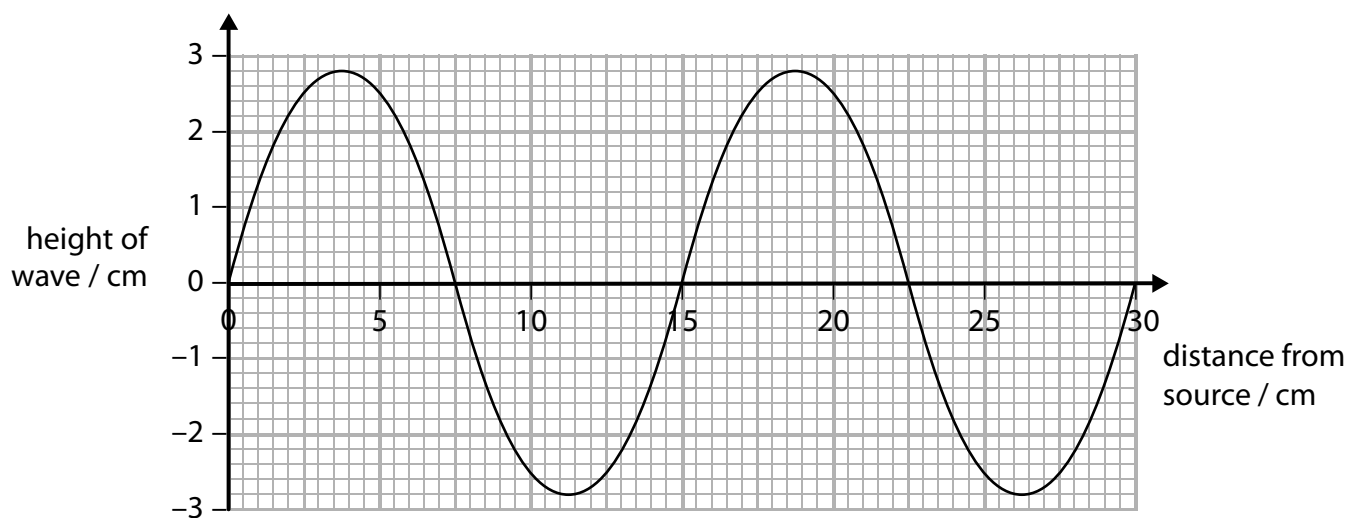

Figure 2

(i) What is the amplitude of this wave?

(1)

- A 2.8 cm
- B 5.6 cm
- C 7.5 cm
- D 15 cm

(ii) What is the wavelength of this wave?

(1)

- A 2.8 cm
- B 7.5 cm
- C 15 cm
- D 30 cm

(c) Water waves are transverse waves.

(i) Give **one** other example of a transverse wave.

(1)

(ii) Give **one** example of a longitudinal wave.

(1)

(d) An earthquake causes a sea wave.

This sea wave travels 26 400 m in two minutes.

Calculate the speed of the wave.

Use the equation

$$\text{wave speed} = \frac{\text{distance}}{\text{time}}$$

(3)

speed = m/s

(Total for Question 2 = 9 marks)

3 There are many different types of waves.

(a) Waves on the surface of water are transverse waves.

Sound waves are longitudinal waves.

Describe the difference between transverse waves and longitudinal waves.

(2)

.....

.....

.....

.....

(b) Figure 1 shows a ripple tank.

This is used to study the behaviour of water waves.

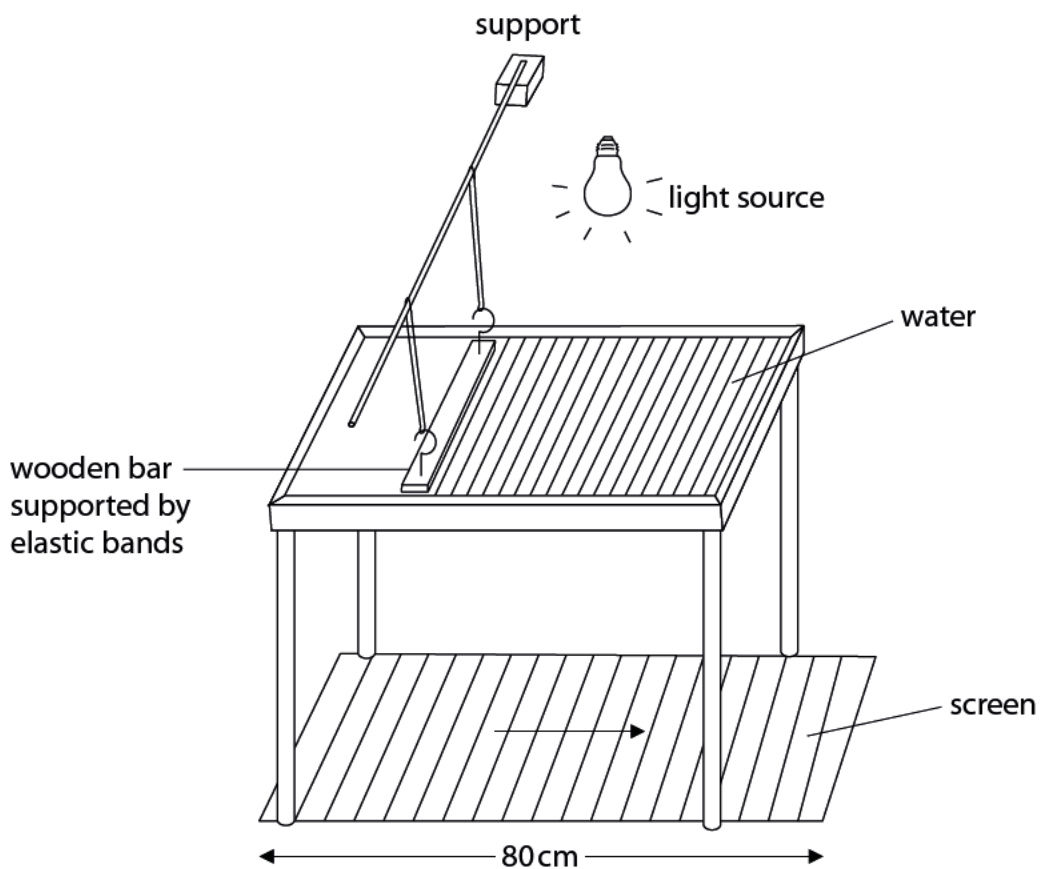

Figure 1

Water waves are produced in the tank.

The shadow of the waves is projected onto the screen below the tank.

The waves appear to move in the direction of the arrow.

(i) Describe how to determine the frequency of the waves.

(2)

.....

.....

.....

.....

(ii) The screen is 80 cm long.

What is the approximate wavelength of the waves as seen on the screen?

(1)

- A 4 cm
- B 8 cm
- C 40 cm
- D 80 cm

(iii) A student uses the image to estimate the speed of the water wave as 75 cm/s.

Which of these is a reason why the estimate is not correct?

(1)

- A the student used a ruler without mm markings
- B the light was not bright enough
- C the student's measurement was inaccurate
- D the wave seen on the screen is magnified

(Total for Question 1 = 6 marks)

Visible light

4 Mirrors and lenses can be used in telescopes.

(a) Which diagram best shows what happens to a ray of light when it hits a plane mirror?

Put a cross (☒) in the box next to your answer.

(1)

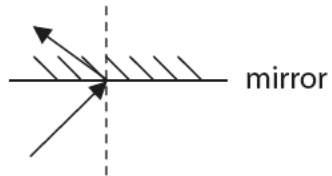

A

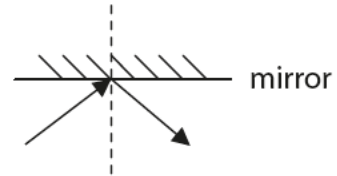

B

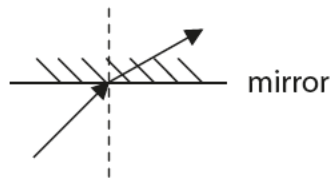

C

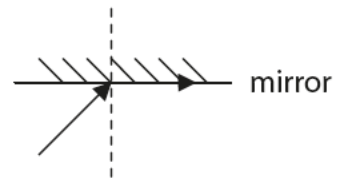

D

(b) The diagram shows light rays in a reflecting telescope.

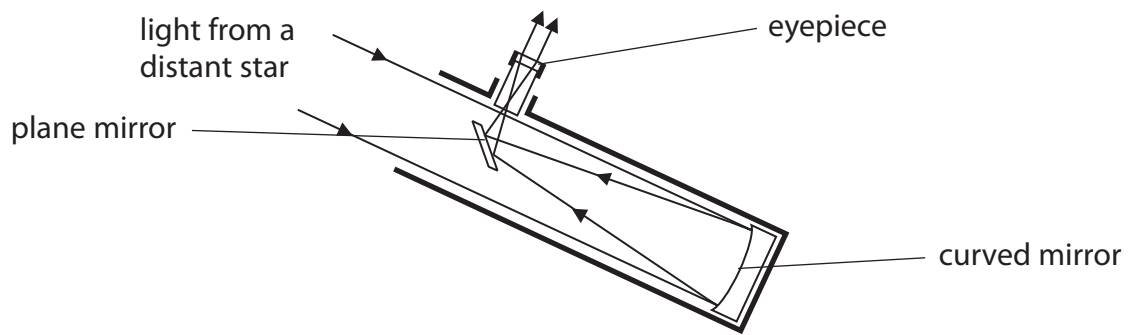

(i) Describe what the mirrors and the eyepiece do to the light rays to form an image of a distant star.

(3)

.....

.....

.....

.....

.....

.....

(ii) Explain an advantage of using a telescope instead of the naked eye to look at stars.

(2)

.....

.....

.....

.....

- (c) Light travels through space as a wave.
A model of this type of wave can be made using a Slinky spring.
A Slinky spring is a long coil of wire like the one shown in the diagram.

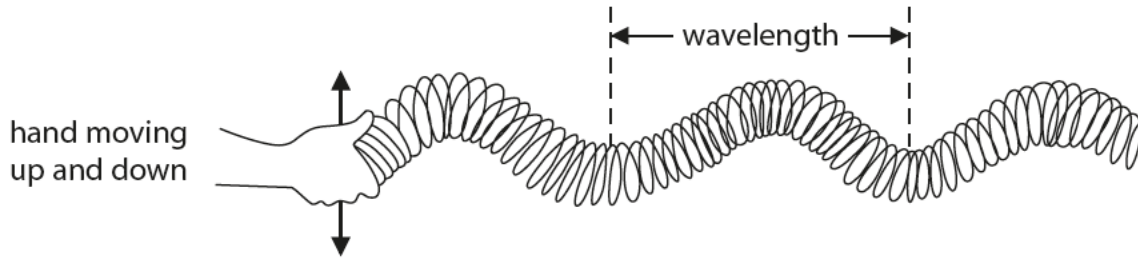

- (i) State the name of this type of wave.

(1)

-
- (ii) How could the movement of the hand be changed to make the amplitude of this wave bigger?

Put a cross (☒) in the box next to your answer.

(1)

- A** move up and down a smaller distance
- B** move up and down at a faster rate
- C** move up and down a bigger distance
- D** move up and down at a slower rate

- (iii) The wave shown in the model has a wavelength of 0.5 m and the frequency is 4 Hz.

Calculate the speed of the wave.

(2)

speed of wave = m/s

(Total for Question 3 = 10 marks)

Lamps

5 This lamp has a wire filament that glows white hot when it is in use.

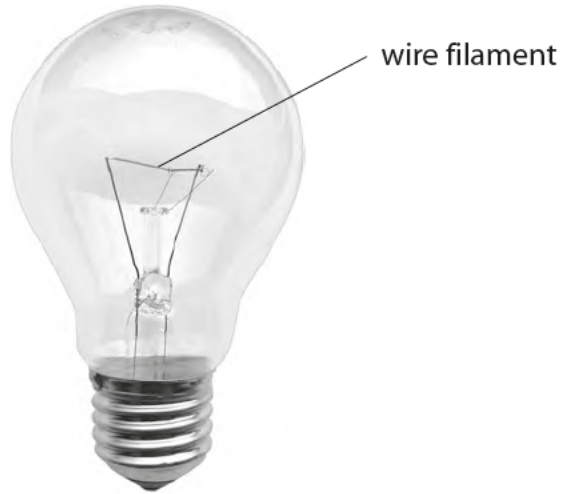

(a) A 100 W filament lamp is 15% efficient.

(i) Explain the meaning of the term **15% efficient**.

(2)

.....

.....

.....

.....

(ii) Draw a labelled energy flow diagram to show what happens to 100 J of electrical energy supplied to the lamp.

(2)

(b) Many people choose to buy expensive low-energy lamps instead of cheaper filament lamps.

Give **two** reasons for this.

(2)

.....

.....

.....

.....

(c) When a filament lamp is in use, the temperature of the wire filament remains at 2500 °C.

Explain why this temperature remains constant.

(3)

.....

.....

.....

.....

.....

.....

(Total for Question 2 = 9 marks)